



Table Of Contents

Equations and Tables	2	Accucal® Precision Flowmeters	8-9
Important Information on Rotameters	3	Industrial Flowmeters	10-11
Laboratory Flowmeter	4-5	Air - 0 to 60 SLPM	
Air - 0.02 ml/min to 675 LPM		Water - 0 to 1,800 ml/min	
Water - 0.0002 ml/min to 20 LPM		Industrial Flowmeters	12-13
Certification Services	6	Framed	
Laboratory Flowmeter Kits	6	Air - 20 to 900 SLPM	
Replacement Shields and Flowtubes	6	Water - 0.5 to 20 LPM	
Flow Rate Analysis Software	7	Acrylic	
		Air - 400 to 3400 SLPM	
		Water - 5 to 75 LPM	
		Fittings	14-15

Specific Gravity Correction Factors																	
Gas Meter is Calibrated With	Gas Being Used																
	Hydrogen	Helium	Methane	Ammonia	Neon	Acetylene	Nitrogen/Carbon Monoxide	Ethylene	Air	Ethane	Oxygen	Hydrogen Sulfide	Argone	Nitrous / Carbon Dioxide	Propane	Butane	Sulfur Dioxide
Hydrogen	1	0.70	0.35	0.34	0.32	0.28	0.27	0.27	0.26	0.26	0.25	0.24	0.22	0.21	0.21	0.18	0.18
Helium	1.41	1	0.50	0.48	0.45	0.38	0.38	0.38	0.37	0.36	0.35	0.34	0.32	0.30	0.30	0.26	0.25
Methane	2.82	2	1	0.97	0.89	0.78	0.76	0.75	0.74	0.73	0.71	0.68	0.63	0.60	0.59	0.52	0.49
Ammonia	2.92	2.06	1.03	1	0.92	0.81	0.78	0.78	0.77	0.75	0.73	0.70	0.66	0.62	0.62	0.54	0.51
Neon	3.17	2.25	1.12	1.08	1	0.88	0.85	0.84	0.83	0.82	0.80	0.76	0.71	0.67	0.67	0.58	0.55
Acetylene	3.62	2.56	1.28	1.24	1.14	1	0.97	0.96	0.95	0.93	0.91	0.87	0.81	0.77	0.76	0.66	0.63
Nitrogen/Carbon Monoxide	3.74	2.64	1.32	1.28	1.18	1.03	1	1	0.98	0.96	0.94	0.90	0.84	0.80	0.79	0.68	0.65
Ethylene	3.74	2.66	1.33	1.26	1.18	1.03	1	1	1.01	0.96	0.94	0.90	0.84	0.80	0.79	0.69	0.66
Air	3.61	2.69	1.35	1.30	1.20	1.04	1.02	1.01	1	0.98	0.95	0.92	0.85	0.81	0.80	0.70	0.66
Ethane	3.90	2.76	1.38	1.33	1.23	1.08	1.04	1.04	1.02	1	0.98	0.94	0.88	0.83	0.82	0.71	0.68
Oxygen	4	2.82	1.41	1.36	1.26	1.10	1.06	1.06	1.05	1.02	1	0.95	0.90	0.85	0.84	0.73	0.70
Hydrogen Sulfide	4.15	2.94	1.47	1.42	1.31	1.15	1.11	1.11	1.09	1.06	1.04	1	0.93	0.88	0.88	0.76	0.72
Argon	4.45	3.15	1.58	1.52	1.40	1.23	1.19	1.18	1.17	1.14	1.12	1.07	1	0.94	0.94	0.82	0.78
Nitrous Oxide / Carbon Dioxide	4.70	3.33	1.67	1.61	1.48	1.30	1.26	1.25	1.24	1.21	1.18	1.13	1.06	1	0.99	0.88	0.82
Propane	4.76	3.36	1.68	1.63	1.50	1.31	1.27	1.26	1.25	1.22	1.19	1.15	1.07	1.01	1	0.87	0.83
Butane	5.46	3.66	1.93	1.67	1.72	1.51	1.46	1.45	1.43	1.40	1.37	1.32	1.22	1.16	1.15	1	0.95
Sulfur Dioxide	5.72	4.05	2.03	1.96	1.81	1.58	1.53	1.52	1.50	1.47	1.43	1.38	1.28	1.22	1.20	1.05	1

Multiply Reading By	Flowmeter Pressure Correction																				
	Working Pressure of Flowmeter - PSIG																				
Pressure at Which Meter Was Calibrated - PSIG	0	0	5	10	15	20	25	30	35	40	45	50	60	70	75	80	90	100	110	120	130
	0	1	1.15	1.29	1.41	1.53	1.64	1.74	1.84	1.93	2.02	2.1	2.26	2.4	2.47	2.54	2.67	2.8	2.92	3.03	3.14
	5	.86	1	1.12	1.23	1.33	1.42	1.51	1.59	1.67	1.74	1.81	1.94	2.07	2.13	2.19	2.31	2.42	2.52	2.62	2.71
	10	.77	.89	1	1.1	1.19	1.27	1.35	1.42	1.49	1.56	1.62	1.74	1.85	1.91	1.96	2.06	2.16	2.25	2.33	2.41
	15	.7	.81	.91	1	1.08	1.16	1.23	1.3	1.36	1.42	1.48	1.59	1.69	1.74	1.79	1.88	1.97	2.05	2.13	2.21
	20	.65	.75	.84	.92	1	1.07	1.14	1.2	1.26	1.31	1.36	1.46	1.56	1.61	1.65	1.74	1.82	1.9	1.97	2.04
	25	.61	.7	.78	.86	.93	1	1.06	1.12	1.18	1.23	1.28	1.37	1.46	1.5	1.54	1.62	1.7	1.77	1.84	1.91
	30	.57	.66	.74	.81	.88	.94	1	1.05	1.1	1.15	1.2	1.29	1.38	1.42	1.46	1.53	1.6	1.67	1.74	1.8
	35	.54	.63	.71	.78	.84	.90	.95	1	1.05	1.1	1.14	1.22	1.3	1.34	1.38	1.46	1.53	1.59	1.65	1.71
	40	.52	.6	.67	.74	.8	.85	.9	.95	1	1.04	1.09	1.17	1.25	1.28	1.32	1.39	1.45	1.51	1.57	1.63
	45	.5	.57	.64	.71	.76	.81	.86	.91	.96	1	1.04	1.12	1.19	1.23	1.26	1.33	1.39	1.45	1.5	1.56
50	.48	.55	.62	.68	.73	.78	.83	.88	.92	.96	1	1.07	1.15	1.18	1.21	1.28	1.33	1.39	1.44	1.5	
60	.44	.51	.57	.63	.68	.73	.77	.82	.86	.89	.93	1	1.06	1.10	1.13	1.19	1.24	1.3	1.35	1.4	
75	.4	.47	.52	.58	.62	.67	.71	.75	.78	.82	.85	.91	.97	1	1.03	1.08	1.13	1.18	1.23	1.27	
100	.36	.41	.46	.51	.55	.59	.63	.66	.69	.72	.75	.81	.86	.89	.91	.95	1	1.04	1.08	1.12	

Important Information on Rotometers

The Variable-Area type flowmeter, or Rotameter, is one of the most economical and reliable of flow measurement instruments. In various configurations it can be designed to withstand high pressures, corrosive fluids, high temperatures, and is completely independent of factors influencing electronic meters.

They can be calibrated to measure nearly any gas or liquid, because their principles of operation are simple and well understood. The flow indication is obtained from a balance of the fluid forces underneath the float with gravity.

This is done using a uniformly tapered tube, a float whose diameter is nearly identical to the tube ID at the inlet, and a scale to correlate float height. The flow tube is traditionally placed in a vertical position and fluid enters from the bottom, forcing the float up in the tube until a sufficient annular opening exists between the float and tube to allow the total volume of fluid to flow past the float. At this point the float is in an equilibrium position and its height is proportional to the flow rate.

With this in mind, many simple factors influencing rotameter performance are easily understood. For example, increasing the density and weight of the float will require a higher flow rate to force the ball up to any height in the tube. In addition, it is easy to see that any changes in the fluid caused by temperature or pressure will affect the float's position. This is particularly true for gases which are compressible, and are, therefore, greatly affected by operating pressures. Studies over the years have resulted in many correlation equations or methods for correcting for gas density, pressure, temperature and viscosity. Some of the more common formulas are shown below.

Figure 1 Rotameter tube.

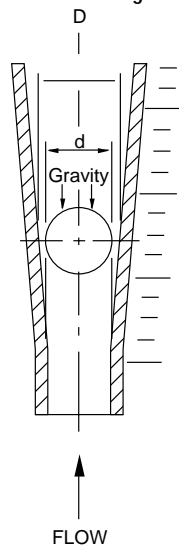

General Correction equations for approximating gas or liquid flow from air or water flow readings.

Corrections for Gas Flow

Gas Flow from Air Flow:

$$q_G^\circ = q_A^\circ \sqrt{\frac{.00120}{p_G^\circ}}$$

Corrections for Temperature and Pressure:

$$q_G' = q_G^\circ \sqrt{\frac{P}{760} \cdot \frac{530}{T}}$$

Corrections for Liquid Flow

Liquid Flow from Water Flow:

$$q_L^\circ = q_W^\circ \sqrt{\frac{p_f - p_L^\circ}{(p_f - 1) p_L^\circ}}$$

Correction for Temperature

(Note: for liquids the effect of pressure is negligible):

$$q_L' = q_W^\circ \sqrt{\frac{p_f}{p_f} \cdot \frac{p_L'}{p_L^\circ} \cdot \frac{p_L'}{p'}}$$

1. Definition of terms

Standard Conditions – P = 1 ATM T = 70°F

OPERATING CONDITIONS–

P = Absolute pressure of gas inlet in mm of Hg

T = Absolute temperature in °R = °F + 460

FLOW TERMS–

q_A° = std. air flow reading from meter

q_G° = std. gas flow in same units

q_G' = gas flow at P and T with volume corrected to measurement at std. cond.

q_W° = std. water flow reading from meter

q_L° = std. liquid flow in same units

q_L' = liquid flow at T with volume corrected measurement at std. cond.

Density Terms–

p_G° = density of gas in gm/ml at std. cond.

p_L° = density of liquid in gm/ml at std. cond.

p_L' = density of liquid in gm/ml at T

p_f = density of float = 2.53 for glass, 3.98 for ruby, 8.02 for stainless steel, 14.9 for tungsten carbide

Viscosity Terms–

μ_G° = viscosity of gas in cp at std. cond.

μ_L° = viscosity of liquid in cp at std. cond.

μ_L' = viscosity of liquid in cp at T

As you can see from these equations, a pressure increase of 50 psig will more than double the flow rate indicated by the float height in a rotameter. It is important to remember that the working pressure is considered to be at the outlet of the tube when the valve is at the inlet. Conversely, if the valve is installed at the outlet, the working pressure is at the inlet. This is done to reference the operating conditions to those at calibration of the rotameter.

Rotameter accuracy is dependent on the accuracy of the pressure, temperature and flow control during calibration, and operation. Gilmont® meters are designed to extremely tight tolerances in materials. This is combined with highly accurate and precise calibration procedures which allows our meters to be rated at errors of as little as ± 2.0% of reading or ± one scale division. It should be pointed out that this is significantly better than many of our competitor's meters which are rated to no better than ± 5.0% "Full Scale". This simply means that for a unit with a Full Scale flow rate of 1000 sccm, the readings from this meter are no better than ± 50 sccm. This is true even at 200 sccm, where the error will be 25%. This exponential increase in % error limits the useful range of the meter. A good guide when specifying a rotameter for any application is to target the upper half of the scale for your flow range.

In addition, based on Dr. Roger Gilmont's extensive 30 year research we are able to correlate flows using a unique data analysis program which can correct for specific operating conditions. Our GF-4000 Flow Rate Analysis Program appears on page 7 of our catalog. Please refer to our Technical Reference Book for Reprints of some of Dr. Gilmont's papers and studies.

Laboratory Flowmeters

- **Wide selection of flow ranges**—measure air from 0.02 ml/min to 675 LPM or water from 0.0002 ml/min to 20 LPM
- **High-accuracy correlated flowmeters**— ±2% of reading!
- **Excellent chemical compatibility with glass and PTFE construction**



Unshielded Flowmeters

Choose unshielded flowmeters for high purity and corrosion resistance in low-pressure applications. PTFE stops accept taper joints (order from page 7) to make quick glass-to-glass connections. Unshielded flowmeters feature small outside diameters—meters require minimal space.

Shielded Flowmeters

Use these flowmeters for higher pressure applications. The clear polycarbonate shield adds strength and protects the tube from damage. Fluid contacts only the borosilicate glass tube, PTFE body, and VITON® fluoroelastomer O-rings—not the polycarbonate shield. End bushings are polypropylene with PTFE inserts. Order coupling adapters on facing page to prevent fluid from contacting the end bushings.

Shielded Flowmeters with Valves

Choose these flowmeters for greater control; micrometer capillary valves ensure precise, reproducible measurement and flow control. Shields are clear polycarbonate; valve consists of a precision-bore glass tube for the fluid and a precision-ground rod of PCTFE (PTFE for sizes 4, 5, 14, and 15) controlled by a micrometer. The 20-turn micrometer valve can be adjusted from 0.1 to 100% of maximum flow—control is semilogarithmic. Precise regulation can be obtained through 19.5 turns (0.3 to 60% of maximum flow). You can interchange flowtubes among valve assemblies of the same size.

Direct Reading Flowmeters

Take air and water readings directly with these compact meters—no calibration curves needed for glass floats. Accuracy is ±5% of reading or 2 mm of the scale length, whichever is greater.



Tube size	Float included	Flow rate*		Unshielded flowmeters		Shielded flowmeters			Shielded flowmeters with valves		
		Air (ml/min)	Water (ml/min)	Catalog number	Max psi	Catalog number	Ports NPT(M)	Max psi	Catalog number	Ports NPT(M)	Max psi
10	Glass 316 SS	0.2-90 0.36-160	0.002-1.1 0.004-2.3	GF-2000	15	GF-2060	¼"	125	GF-9060	⅛"	125
11	Glass 316 SS	1-280 2-500	0.01-4.0 0.02-8.6	GF-2100	15	GF-2160	¼"	125	GF-9160	⅛"	125
12	Glass 316 SS	20-2100 36-3700	0.4-40 0.86-86	GF-2200	15	GF-2260	¼"	100	GF-9260	⅛"	100
13	Glass 316 SS	200-14,000 360-25,000	2-300 4-640	GF-2300	15	GF-2360	¼"	75	GF-9360	⅛"	75
14	Glass 316 SS	1000-36,000 1800-64,000	10-850 21-1820	GF-2400	15	GF-2460	½"	60	GF-9460	¼"	60
15	Glass 316 SS	3000-77,000 5300-137,000	30-1900 64-4100	GF-2500	15	GF-2560	½"	50	GF-9560	¼"	50

NOTE: For pressure drop of each flowmeter, please call our Application Specialists. *When using stainless steel float, refer to included correlation table for proper reading.

Correlated Flowmeters

Extremely accurate . . . ± 2% of reading or ±1 scale division, whichever is greater. Determine flow values for air and water from the computerized calibration table enclosed with each flowmeter. Tables are included for

floats used with both air and water at STP. A flow chart and formulas are included to convert scale readings for other gases or liquids or for floats other than glass. See page 7 to order our flow analysis software to generate flow charts specific to your individual applications.

Tube size	Float included	Flow rate*		Unshielded flowmeters		Shielded flowmeters			Shielded flowmeters with valves		
		Air (ml/min)	Water (ml/min)	Catalog number	Max psi	Catalog number	Ports NPT	Max psi	Catalog number	Ports NPT	Max psi
Micro	Ruby	0.02-15	0.0002-0.12	GF-3000	15	GF-3060	¼ (M)	125	GF-9760	⅛ (M)	125
0	Glass 316 SS	0.2-100 0.36-180	0.002-1.1 0.004-2.3	GF-1000	15	GF-1060	¼ (M)	125	GF-7060	⅛ (M)	125
1	Glass 316 SS	1-280 2-500	0.01-4.0 0.02-8.6	GF-1100	15	GF-1160	¼ (M)	125	GF-7160	⅛ (M)	125
2	Glass 316 SS	10-1900 20-3400	0.2-36 0.43-77	GF-1200	15	GF-1260	¼ (M)	100	GF-7260	⅛ (M)	100
3	Glass 316 SS	200-14,000 360-25,000	3-300 6-640	GF-1300	15	GF-1360	¼ (M)	75	GF-7360	⅛ (M)	75
4	Glass 316 SS	1000-36,000 1800-64,000	10-850 21-1820	GF-1400	15	GF-1460	½ (M)	60	GF-7460	¼ (M)	60
5	Glass 316 SS	3000-77,000 5300-137,000	30-1900 64-4100	GF-1500	15	GF-1560	½ (M)	50	GF-7560	¼ (M)	50
6	Glass 316 SS	25,000-330,000 50,000-675,000	500-8000 1500-20,000	—	—	GF-1660	½ (F)	50	—	—	—

NOTE: For pressure drop of each flowmeter, please call our Application Specialists. *When using stainless steel float, refer to included correlation table for proper reading.

Specifications

	Direct Reading	Correlated
Accuracy:	± 5% of reading or 2mm of scale length whichever is greater.	± 2% of reading or ± 1 scale division, whichever is greater. For micro: ± 5% of reading or ± 2 scale division (Air); ± 10% of reading or ± 3 scale division (water).
Repeatability:	± 1% of reading or ± 0.5 scale division, whichever is greater.	
Turndown Ratio:	Better than 25:1	
Pressure Rating:	See tables, page 4	
Operating Temperatures:	-15°F to 150°F (-26°C to 65°C) at full pressure rating. Above 150°F(65°C), max. pressure is 40 psig.	
Connections:	Unshielded	Use Taper joint Adapters – See Page 7
	Shielded	3/8" I.D. tubing on Sizes 0-3, and Micro to 13, 5/8" I.D. tubing on Sizes 4-5, and 14 to 15, or see Page 9 for coupling adapters.
	Shielded with Valve	1/8" NPT(M) Sizes 0-3, Micro-13 1/4" NPT(M) Sizes 4-5, 14-15
Shipping Wt:	Unshielded	0.5 lb. (0.3 kg)
	Shielded	1.0 lb. (0.5 kg)
	Shielded with Valve	1.0 lb. (0.5 kg)

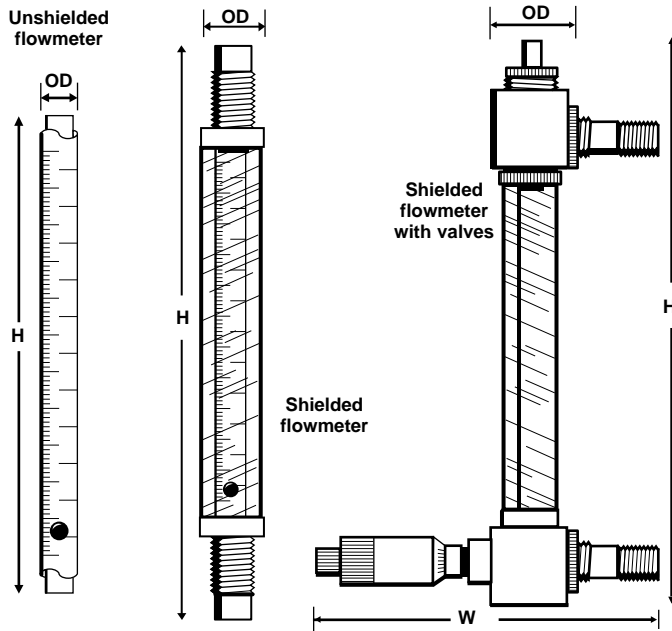

Materials of Construction

Flowtube	Borosilicate glass
Floats	Glass/316 SS (Ruby-micro size only)
End blocks/stops	PTFE
Inlet/Outlet	PTFE
Shield	Acrylic
Shield ends	Polypropylene
Valve	PTFE, PCTFE, Glass
O-rings	Viton®

Dimensions

Tube size(s)	Dimensions		
	Unshielded (H x OD)	Shielded (H x OD)	Shielded with valves (H x W [†] x OD)
Micro	5 1/8" x 5/16"	8" x 1"	8 7/8" x 6" x 1 5/16"
0, 1, 2	7 1/2" x 5/16"	10 1/4" x 1"	11" x 6" x 1 5/16"
3	7 1/2" x 7/16"	10 1/4" x 1"	11" x 6" x 1 5/16"
4	9" x 1 1/16"	13 1/4" x 1 1/2"	14 1/2" x 7" x 1 15/16"
5	9" x 1 5/16"	13 1/4" x 1 1/2"	14 1/2" x 7" x 1 15/16"
6	—	15 1/8" x 1 3/4"	—
10, 11, 12	5 1/8" x 5/16"	8" x 1"	8 7/8" x 6" x 1 5/16"
13	5 1/8" x 7/16"	8" x 1"	8 7/8" x 6" x 1 5/16"
14	5 1/2" x 1 1/16"	9 3/4" x 1 1/2"	11" x 7" x 1 15/16"
15	5 1/2" x 1 5/16"	9 3/4" x 1 1/2"	11" x 7" x 1 15/16"

[†]Width is from terminal end of valve to inlet adapter.

Flowmeter Stand Kit and Components

The flowmeter stand kit contains everything you need to mount your GILMONT® flowmeter on a stand, a benchtop, or a wall. The base is machined from rugged aluminum. A built-in "bubble level" ensures that the base is level for maximum accuracy. Configure base to accept three rod and clamp assemblies for unshielded or shielded flowmeters. Mount valved flowmeters directly—base accepts two large flowmeters (size 4, 5, 14, or 15) or three of the smaller flowmeters. Mounting clamps hold flowmeters firmly in place without obstructing your view of the flowmeter scale or damaging the flowtube or shield.

Clamps are L-shaped with mounting holes bored into them for mounting flowmeters to a wall or panel (wood screws included).

GF-4004 Flowmeter stand kit. Includes one base, one rod, and two mounting clamps

GF-4001 Flowmeter base

GF-4002 Rod, 18"L

GF-4003 Mounting clamp. Includes wood screws

Laboratory Flowmeter Kits

NIST Certs Available

- Measure wide range of flow rates—determine unknown flow rates

Each kit comes complete with flowmeters, glass floats, 316 stainless steel floats, and instructions. See pages 4 and 5 for more information on individual flowmeter features and exact flow ranges. Correlated flowmeter kits include computer-generated correlation sheets for all tubes and floats for air and water at standard temperature and pressure (70°F and 14.7 psig).

Unshielded flowmeter kits can be used with flexible tubing or PTFE coupling adapters. Shielded flowmeter kits come with one interchangeable shield assembly. Shielded flowmeter with valve kits contain one interchangeable shield and valve assembly.

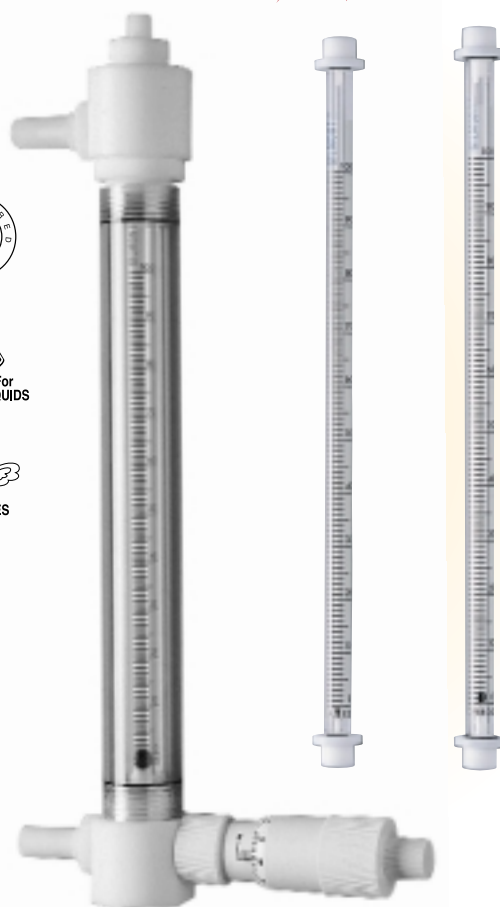

Flowmeter Kits

Catalog number	Type	Flow range (ml/min)*		Flowtube sizes included
		Air	Water	
Correlated flowmeter kits				
GF-6500	Unshielded	1-137,000	0.01-4100	1, 2, 3, 4, and 5
GF-6360	Shielded	1-25,000	0.01-640	1, 2, and 3
GF-6460	Shielded	1000-137,000	10-4100	4 and 5
GF-7660	Shielded with valve	1-25,000	0.01-640	1, 2, and 3
GF-7860	Shielded with valve	1000-137,000	10-4100	4 and 5
Direct-reading flowmeter kits				
GF-8500	Unshielded	0.2-25,000	0.002-640	10, 11, 12, and 13
GF-9500	Unshielded	1000-137,000	10-4100	14 and 15
GF-9960	Shielded with valve	0.02-160	0.0002-2.3	Micro† and 10
GF-9660	Shielded with valve	1-25,000	0.01-640	11, 12, and 13
GF-9860	Shielded with valve	1000-137,000	10-4100	14 and 15

*For specific flow rates, see pages 6 and 7. Flow rates are at standard temperature and pressure.
†Micro tube size is for correlated type only; supplied with a ruby float.

Replacement Shields and Flowtubes

Replacement shields come with a shield tube, two bushings, two inserts, and two O-rings. Use as a replacement for your shielded flowmeter, or add to an unshielded flowmeter to convert for shielded operation. Made of rugged, transparent polycarbonate. Call our Application Specialists for ordering information on replacement shields for flowmeters with valves.

Replacement flowtubes for valved meters come with glass and 316 SS floats (model GF-3069 come with a ruby float only), and the necessary adapters with O-rings to fit valved assembly. Includes a correlation chart for using meter with glass float (ruby float for model GF-3069). To order replacement tube for shielded flowmeter without valve, order the corresponding unshielded flowmeter from pages 4 and 5.

Tube size	Replacement flowtubes	Replacement shields
	Cat. no.	Cat. no.
Micro	GF-3069	GF-3065
0	GF-1069	GF-1065
1	GF-1169	GF-1165
2	GF-1269	GF-1265
3	GF-1369	GF-1365
4	GF-1469	GF-1465
5	GF-1569	GF-1565
10	GF-2069	GF-2065
11	GF-2169	GF-2165
12	GF-2269	GF-2265
13	GF-2369	GF-2365
14	GF-2469	GF-2465
15	GF-2569	GF-2565



Flow Rate Analysis Software - GF-4000 3.0



- **Generate flow tables for your specific flow conditions**
- **Correct for changes in viscosity, density, pressure, and temperature**

Our Flow Rate Analysis Software works with our Accucal and correlated flowmeters. It is an invaluable aid in optimizing applications, and contains the following features;

Pull-down menus are easy to use and understand.

- **SEARCH FOR FLOWMETER** function: allows you to spec out the correct meter for your application BEFORE you order. This gives you one less thing to worry about when procuring many components for new systems.
- **GENERATE FLOWTABLE** allows you to view the exact float-scale position for your nominal flowrates. You can size a meter for the desired headroom above and below the targeted flowrate. Three float options / meter size provide sufficient overlap of flow range capabilities between models.
- **FLUID MENU** allows generations of custom flow tables with automatic temperature and pressure corrections for over 30 gases and 30 liquids. Eliminates errors associated with manual calculations using approximate correlation formulas.
- **UNITS MENU** allows you to work in units you are comfortable with for flow, temperature, pressure, and viscosity.
- **OUTPUT MENU** provides output options for screen, printer, or file.
- **CAL DATA** menu allows for input of factory calibration data for serialized tube-specific data. This feature provides for increased accuracy of flow table data.
- **FIELD CAL MODULE** allows generation of 100 point flowtables based on field cal meter from 3-10 points. Great for applications where density and viscosity are not known, or the fluid is proprietary.
- **CUSTOM DIRECT READING SCALES** can be generated easily on site when used with the Accucal® line of Industrial Flowmeters.
- **COMPLETE PROGRAM INSTRUCTIONS** are contained in the Online Help Files.
- **SYSTEM REQUIREMENTS** Windows® 95/98/NT®, 16 mb ram, 5 mb hard disk space.

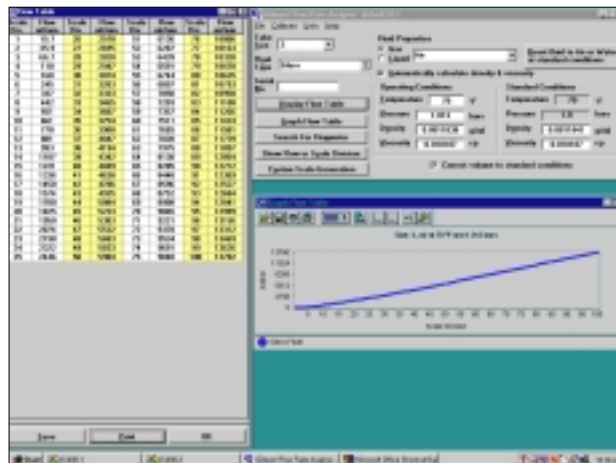

Flow rate analysis software GF-4000

Taper Joints and PTFE Coupling Adapters

Taper Joints and PTFE Coupling Adapters

Taper joints are for unshielded flowmeters. Each set includes a male joint, a female joint, and two O-rings. PTFE coupling adapters attach to threaded bushings on shielded meters and provide an NPT(F) port. Internal PTFE O-ring ensures that fluid won't come in contact with polypropylene bushing. For connection to 3/8" or 1/2" OD tubing, order PTFE pipe-to-tubing adapters below—two adapters are required per flowmeter. For more compression fittings see page 14 and 15.

6374-05 Pipe-to-tubing adapter, 1/4 NPT(M) x 3/8" OD

6374-08 Pipe-to-tubing adapter, 1/2 NPT(M) x 1/2" OD



Taper joint set GF-1121

Cat. no.	Tube size	Connection
Taper joints for unshielded flowmeters		
GF-1121	Micro., 0, 1, 10, and 11	10/30 taper
GF-1221	2 and 12	12/30 taper
GF-1321	3 and 13	14/35 taper
GF-1421	4 and 14	19/38 taper
GF-1521	5 and 15	24/40 taper
PTFE coupling adapters for shielded flowmeters		
GF-4010	Micro., 0, 1, 2, 3, 10, 11, 12, and 13	1/4 NPT(F)
GF-4020	4, 5, 14, and 15	1/2 NPT(F)

GILMONT® Accucal® Flowmeters



- Correlated and direct reading all in one easy-to-read meter
- Accuracy up to $\pm 2\%$ of reading!
- Interchangeable scales—customize your application
- Extremely low pressure drops—ideal for procedures with critical pressure values

Two direct reading scales are included with each flowmeter. (English and metric units)

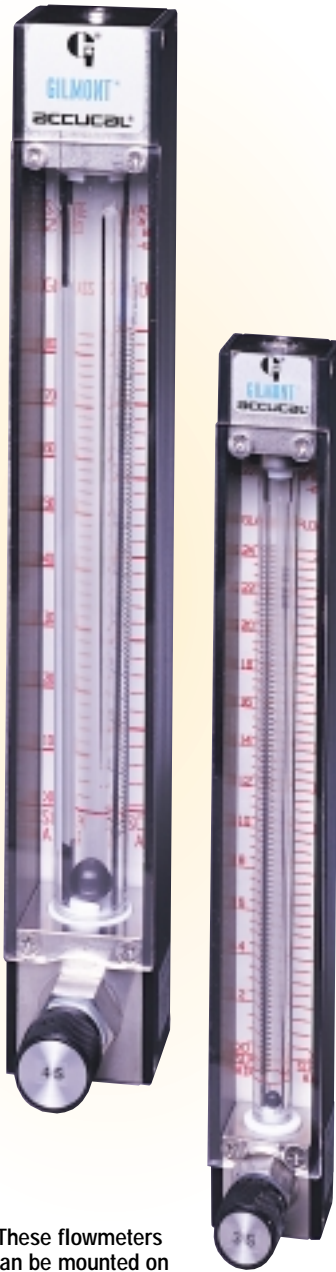

These flowmeters can be mounted on a panel or base.

Correlated and Direct Reading in one easy to use flowmeter. Each meter includes correlation charts for air and water and two direct-reading scales—an air scale and a water scale. Easily change between correlated and direct-reading scales depending on your application. Meters are available in 65mm and 150mm scale lengths.

Each direct-reading scale indicates flow rates in metric and English units, for both glass and stainless steel floats under standard operating conditions. Use the new GF-4000 software to create your own custom scales.

Excellent Accuracy is achieved with our second-generation correlation techniques and the factory calibration of the tube. Accuracy can be expressed as a percent of reading—not of full-scale! With correlated use, accuracy is $\pm 2\%$ of reading or $\pm 1\%$ scale division, whichever is greater. With direct-reading use, ± 2 divisions accuracy is $\pm 5\%$ of reading or ± 3 mm on scale, whichever is greater. All flowtubes have serial numbers for traceability to calibration, accuracy, and manufacturing data.

Accessories

GF-4001 Flowmeter Base is made of rugged aluminum. Mount flowmeters directly—base accepts three flowmeters. Built-in bubble level.

GF-4000 Flowrate Analysis Software makes flow analysis simple. You can produce flow rate tables based on your temperature, pressure, viscosity and density conditions; float material; and the gas or liquid being measured.

Quality Industrial Design ensures use in most tough applications. The clear polycarbonate front shield provides a 90° view of the scales on the stainless meters.

Meters are designed for easy flowtube exchange or replacement. The end stop has a large diameter to let you center the flowtube quickly and more accurately than most flowmeters. All flowtubes are interchangeable within the same frame size. Call our Application Specialist to order a replacement flowtube or to upgrade your unit.

Mount flowmeters on a panel or on our flowmeter base (see below). Invert frame for vacuum applications or when back pressure compensation is required.

Advanced Metering Valves are available with GILMONT® flowmeters. The shallow taper design gives you linear control over 80% of the usable range. Valves are 14-turn.

Float	Max flow rate (ml/min)		Tube size	65mm, 303 stainless steel flowmeters	
	Air	H ₂ O		Without valves	With precision valves
				Cat. no.	Cat. no.
Glass SS	95 230	1.1 4.9	100	GF-6340-1100	GF-6341-1100
Glass SS	280 620	3.9 15	110	GF-6340-1110	GF-6341-1110
Glass SS	1000 2000	17 55	115	GF-6340-1115	GF-6341-1115
Glass SS	2200 4200	43 120	120	GF-6340-1120	GF-6341-1120
Glass SS	6500 12,000	140 360	125	GF-6340-1125	GF-6341-1125
Glass SS	14,000 25,000	320 800	130	GF-4340-1130	GF-4341-1130
Glass SS	25,000 46,000	590 1400	135	GF-4340-1135	GF-4341-1135

NOTE: For pressure drop of each flowmeter, please call our Application Specialists.

Specifications

Accuracy: The greater of $\pm 2\%$ of reading or ± 1 division (correlated use); the greater of $\pm 5\%$ of reading ± 2 division of scale (direct reading use)

Repeatability: $\pm 1\%$ of reading or ± 0.5 scale division, whichever is greater

Turn-down ratio: Better than 25:1

Maximum pressure: 250 psig at 250°F

Maximum operating temperature: 250°F (121°C)

Connections: 1/4" NPT(F) for 240 and 250 tube sizes; 1/8" NPT(F) for all others

Shpg wt: 65mm flowmeters: 1 lb (0.5 kg)

150mm flowmeters: 2 lb (1.0kg)

Materials of construction

Flowmeter type	303 SS
Flowtube	Borosilicate glass
Floats*	Glass/316 SS
End blocks	303 SS
Inlet/outlet connections	303 SS
Valve	PCTFE/PTFE (303 SS PCTFE/PTFE for tube sizes 240 and 250)
O-rings	Viton®

*Other Floats/materials available. Call our application specialists for details.

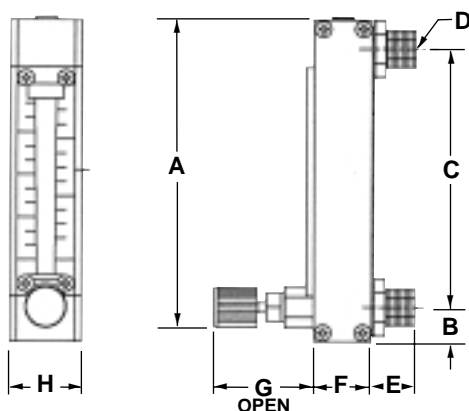

Mount these flowmeters on a panel or base.

Flowmeter base GF-4001

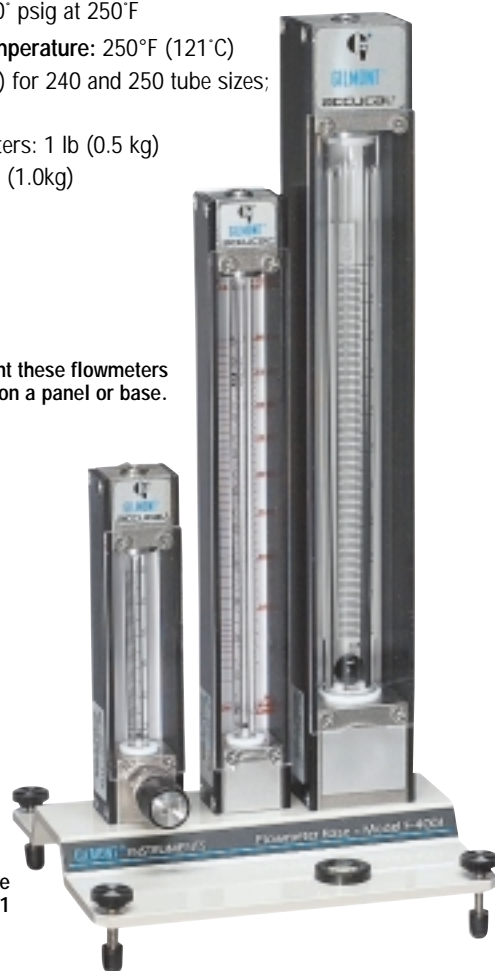

Flowmeter	Dimensions-inches (mm)							
	A	B	C	D	E	F	G	H
65 mm scale (all tube sizes)	5.65 (143.5)	0.60 (15.2)	4.50 (114.3)	1/8-.27 NPT	0.78 (19.8)	1.00 (25.4)	1.75 (44.4)	1.25 (31.7)
150 mm scale (200-235 tubes)	10.02 (254.5)	0.60 (15.2)	8.81 (223.8)	1/8-.27 NPT	0.78 (19.8)	1.00 (25.4)	1.75 (44.4)	1.25 (31.7)
150 mm scale (240-250 tubes)	12.64 (321.1)	0.79 (20.1)	11.00 (279.4)	1/4-.27 NPT	0.95 (24.1)	1.50 (38.1)	2.13 (54.1)	1.75 (44.4)

Ask about our Flow rate analysis software and NIST certs

Float	Max flow rate (ml/min)		Tube size	150-mm, 303 stainless steel flowmeters	
	Air	H ₂ O		Without valves	With precision valves
				Cat. no.	Cat. no.
Glass	95	1.1	200	GF-6540-1200	GF-6541-1200
	230	4.9			
SS	280	3.9	210	GF-6540-1210	GF-6541-1210
	620	15			
Glass	1000	17	215	GF-6540-1215	GF-6541-1215
	2000	55			
Glass	2200	43	220	GF-6540-1220	GF-6541-1220
	4200	120			
Glass	6500	140	225	GF-6540-1225	GF-6541-1225
	12,000	360			
Glass	14,000	320	230	GF-6540-1230	GF-6541-1230
	25,000	800			
Glass	25,000	590	235	GF-6540-1235	GF-6541-1235
	46,000	1400			
Glass	40,000	960	240	GF-6540-1240	GF-6541-1240
	73,000	2200			
Glass	85,000	2000	250	GF-6540-1250	GF-6541-1250
	150,000	4700			

OEM
1-800-637-3739

Applications

- Research & Development laboratories
- Field calibration of instrumentation
- Gas chromatography
- Atomic absorption
- Cylinder gas metering
- Air & water pollution analysis
- Chemical processing
- Paper manufacturing
- Purge systems
- Controlled environments
- Universities
- Petrochemical

Max Flow SML / min	NO VALVE					STANDARD VALVE Flowmeters are supplied with a 8-turn inter-changeable metering valve.			HIGH ACCURACY VALVE For very critical flow regulation or adjustment a 16-turn interchangeable metering valve is supplied.		
	Air	WATER	ALUMINUM	BRASS	STAINLESS STEEL	ALUMINUM	BRASS	STAINLESS STEEL			
8.1 - 145	0.1 - 2.4	GF-8320-1001	GF-8330-1001	GF-8340-1001	GF-8321-1001	GF-8331-1001	GF-8341-1001				
30.2 - 298	0.46 - 7.7	GF-8320-1002	GF-8330-1002	GF-8340-1002	GF-8321-1002	GF-8331-1002	GF-8341-1002				
45 - 522	0.8 - 12	GF-8320-1101	GF-8330-1101	GF-8340-1101	GF-8321-1101	GF-8331-1101	GF-8341-1101				
28 - 1249	0.6 - 27	GF-8320-1201	GF-8330-1201	GF-8340-1201	GF-8321-1201	GF-8331-1201	GF-8341-1201				
90 - 2520	3.7 - 71	GF-8320-1202	GF-8330-1202	GF-8340-1202	GF-8321-1202	GF-8331-1202	GF-8341-1202				
845 - 6318	4 - 147	GF-8320-1401	GF-8330-1401	GF-8340-1401	GF-8321-1401	GF-8331-1401	GF-8341-1401				
1973 - 12058	42 - 364	GF-8320-1402	GF-8330-1402	GF-8340-1402	GF-8321-1402	GF-8331-1402	GF-8341-1402				
2272 - 24680	127 - 745	GF-8320-1501	GF-8330-1501	GF-8340-1501	GF-8321-1501	GF-8331-1501	GF-8341-1501				
6082 - 58500	176 - 1866	GF-8320-1502	GF-8330-1502	GF-8340-1502	GF-8321-1502	GF-8331-1502	GF-8341-1502				

Air	WATER	ALUMINUM	BRASS	STAINLESS STEEL	ALUMINUM	BRASS	STAINLESS STEEL			
5 - 100		GF-8320-2009	GF-8330-2009	GF-8340-2009	GF-8321-2009	GF-8331-2009	GF-8341-2009			
20 - 250		GF-8320-2010	GF-8330-2010	GF-8340-2010	GF-8321-2010	GF-8331-2010	GF-8341-2010			
20 - 500		GF-8320-2109	GF-8330-2109	GF-8340-2109	GF-8321-2109	GF-8331-2109	GF-8341-2109			
100 - 1000		GF-8320-2110	GF-8330-2110	GF-8340-2110	GF-8321-2110	GF-8331-2110	GF-8341-2110			
500 - 10000		GF-8320-2410	GF-8330-2410	GF-8340-2410	GF-8321-2410	GF-8331-2410	GF-8341-2410			
2000 - 40000		GF-8320-2510	GF-8330-2510	GF-8340-2510	GF-8321-2510	GF-8331-2510	GF-8341-2510			
	0.025 - 0.5	GF-8320-2004	GF-8321-2004	GF-8330-2004	GF-8331-2004	GF-8340-2004	GF-8341-2004			
	0.4 - 6	GF-8320-2014	GF-8330-2014	GF-8340-2014	GF-8321-2014	GF-8331-2014	GF-8341-2014			
	1 - 25	GF-8320-2114	GF-8330-2114	GF-8340-2114	GF-8321-2114	GF-8331-2114	GF-8341-2114			
	5 - 60	GF-8320-2214	GF-8330-2214	GF-8340-2214	GF-8321-2214	GF-8331-2214	GF-8341-2214			
	20 - 250	GF-8320-2414	GF-8330-2414	GF-8340-2414	GF-8321-2414	GF-8331-2414	GF-8341-2414			
	100 - 1500	GF-8320-2516	GF-8330-2516	GF-8340-2516	GF-8321-2516	GF-8331-2516	GF-8341-2516			

Air	WATER	ALUMINUM	BRASS	STAINLESS STEEL	ALUMINUM	BRASS	STAINLESS STEEL	ALUMINUM	BRASS	STAINLESS STEEL
8.1 - 140	0.12 - 2.34	GF-8520-1100	GF-8530-1100	GF-8540-1100	GF-8521-1100	GF-8531-1100	GF-8541-1100	GF-8522-1100	GF-8532-1100	GF-8542-1100
33 - 264	0.28 - 4.7	GF-8520-1200	GF-8530-1200	GF-8540-1200	GF-8521-1200	GF-8531-1200	GF-8541-1200	GF-8522-1200	GF-8532-1200	GF-8542-1200
70 - 825	0.8 - 16	GF-8520-1300	GF-8530-1300	GF-8540-1300	GF-8521-1300	GF-8531-1300	GF-8541-1300	GF-8522-1300	GF-8532-1300	GF-8542-1300
201 - 1682	3.5 - 46	GF-8520-1406	GF-8530-1406	GF-8540-1406	GF-8521-1406	GF-8531-1406	GF-8541-1406	GF-8522-1406	GF-8532-1406	GF-8542-1406
480 - 4562	5.4 - 133	GF-8520-1500	GF-8530-1500	GF-8540-1500	GF-8521-1500	GF-8531-1500	GF-8541-1500	GF-8522-1500	GF-8532-1500	GF-8542-1500
288 - 7590	6 - 217	GF-8520-1606	GF-8530-1606	GF-8540-1606	GF-8521-1606	GF-8531-1606	GF-8541-1606	GF-8522-1606	GF-8532-1606	GF-8542-1606
462 - 22536	15 - 541	GF-8520-1700	GF-8530-1700	GF-8540-1700	GF-8521-1700	GF-8531-1700	GF-8541-1700	GF-8522-1700	GF-8532-1700	GF-8542-1700
3542 - 59494	103 - 1881	GF-8520-1800	GF-8530-1800	GF-8540-1800	GF-8521-1800	GF-8531-1800	GF-8541-1800	GF-8522-1800	GF-8532-1800	GF-8542-1800

Air	WATER	ALUMINUM	BRASS	STAINLESS STEEL	ALUMINUM	BRASS	STAINLESS STEEL	ALUMINUM	BRASS	STAINLESS STEEL
1 - 100		GF-8520-2117	GF-8530-2117	GF-8540-2117	GF-8521-2117	GF-8531-2117	GF-8541-2117	GF-8522-2117	GF-8532-2117	GF-8542-2117
20 - 200		GF-8520-2217	GF-8530-2217	GF-8540-2217	GF-8521-2217	GF-8531-2217	GF-8541-2217	GF-8522-2217	GF-8532-2217	GF-8542-2217
50 - 800		GF-8520-2317	GF-8530-2317	GF-8540-2317	GF-8521-2317	GF-8531-2317	GF-8541-2317	GF-8522-2317	GF-8532-2317	GF-8542-2317
200 - 2500		GF-8520-2417	GF-8530-2417	GF-8540-2417	GF-8521-2417	GF-8531-2417	GF-8541-2417	GF-8522-2417	GF-8532-2417	GF-8542-2417
400 - 4800		GF-8520-2517	GF-8530-2517	GF-8540-2517	GF-8521-2517	GF-8531-2517	GF-8541-2517	GF-8522-2517	GF-8532-2517	GF-8542-2517
800 - 10000		GF-8520-2617	GF-8530-2617	GF-8540-2617	GF-8521-2617	GF-8531-2617	GF-8541-2617	GF-8522-2617	GF-8532-2617	GF-8542-2617
1000 - 23000		GF-8520-2717	GF-8530-2717	GF-8540-2717	GF-8521-2717	GF-8531-2717	GF-8541-2717	GF-8522-2717	GF-8532-2717	GF-8542-2717
5000 - 60000		GF-8520-2817	GF-8530-2817	GF-8540-2817	GF-8521-2817	GF-8531-2817	GF-8541-2817	GF-8522-2817	GF-8532-2817	GF-8542-2817
	0.5 - 10	GF-8520-2227	GF-8530-2227	GF-8540-2227	GF-8521-2227	GF-8531-2227	GF-8541-2227	GF-8522-2227	GF-8532-2227	GF-8542-2227
	1 - 20	GF-8520-2327	GF-8530-2327	GF-8540-2327	GF-8521-2327	GF-8531-2327	GF-8541-2327	GF-8522-2327	GF-8532-2327	GF-8542-2327
	1 - 50	GF-8520-2427	GF-8530-2427	GF-8540-2427	GF-8521-2427	GF-8531-2427	GF-8541-2427	GF-8522-2427	GF-8532-2427	GF-8542-2427
	10 - 200	GF-8520-2627	GF-8530-2627	GF-8540-2627	GF-8521-2627	GF-8531-2627	GF-8541-2627	GF-8522-2627	GF-8532-2627	GF-8542-2627
	20 - 500	GF-8520-2727	GF-8530-2727	GF-8540-2727	GF-8521-2727	GF-8531-2727	GF-8541-2727	GF-8522-2727	GF-8532-2727	GF-8542-2727
	150 - 1200	GF-8520-2827	GF-8530-2827	GF-8540-2827	GF-8521-2827	GF-8531-2827	GF-8541-2827	GF-8522-2827	GF-8532-2827	GF-8542-2827

Industrial Flowmeters

NIST Certs Available

- These meters have dual scales Air & Water

127 mm Direct Reading

This series provides liquid and gas flow readings at capacity levels to 20 LPM. While maintaining accuracy of $\pm 5\%$ of full scale. The meter is designed to withstand the physical abuse and environmental corrosion of industrial applications.

A one-piece aluminum frame provides maximum meter protection and safety. The precision taper of the tube and integral float guides ensure float fidelity. The etched glass is rotatable to reveal either the air or water direct-reading scale.

Construction

Wetted End Blocks, Fittings and Internal Parts – Brass or 316 SS

Internal Parts – Brass or 316 SS

Seal Materials – Viton®

Meter Case – Black Painted Aluminum with Acrylic Window

Metering Tube – Borosilicate Glass

Piping Connections – Brass or 316 SS 3/8 NPT(F)

Float materials – 316 SS

Scale – Rotatable, direct reading for air (SCFM-SLPM) and water (GPM-LPM)



127 mm Flowmeter Dimensional Drawing

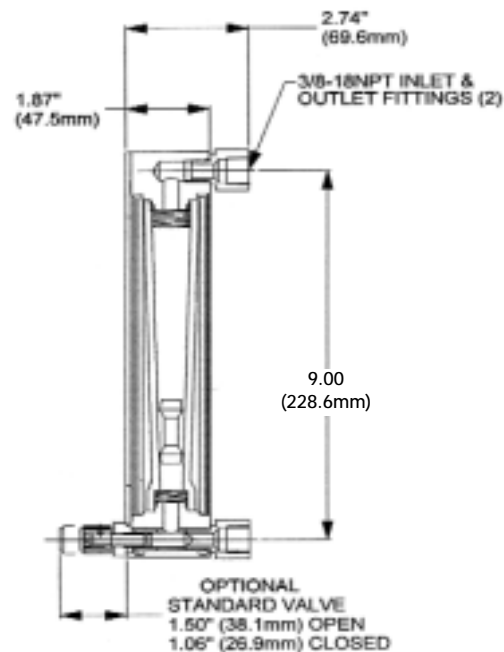
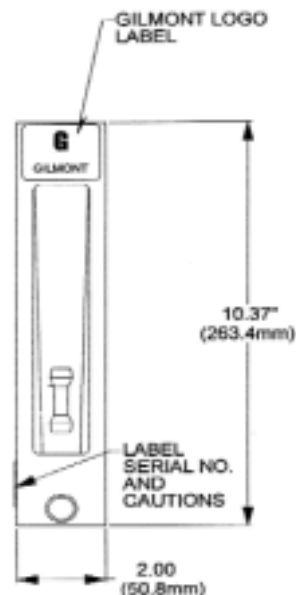

Specifications

Pressure Rating: 150 psig @ 200°F max. operating.

Temperature Rating: 250°F max. operating.

Accuracy: $\pm 5\%$ full scale.

Range: 10 to 1, i.e., 100% to 10% of full scale.

Scale Length: 127mm

FLOW RATE L/MIN		NO VALVE		STANDARD VALVE	
Air	WATER	BRASS	STAINLESS STEEL	BRASS	STAINLESS STEEL
20 – 140	0.5 – 4	GF-8430-2125	GF-8440-2125	GF-8431-2125	GF-8441-2125
30 – 280	1 – 8	GF-8430-2126	GF-8431-2126	GF-8440-2126	GF-8441-2126
25 – 425	1 – 11	GF-8430-2127	GF-8440-2127	GF-8431-2127	GF-8441-2127
25 – 575	1 – 15	GF-8430-2128	GF-8440-2128	GF-8431-2128	GF-8441-2128
50 – 900	1 – 20	GF-8430-2129	GF-8431-2129	GF-8440-2129	GF-8441-2129

Industrial High Flow

- Durable one-piece design for rugged applications
- Direct reading for liquids and air
- Easy to read English or Metric scales

Specifications

Accuracy: ± 2% Full Scale
Repeatability: ± 0.5% Full Scale
Maximum Operating Temperature: 150°F (65°C)
Maximum Operating Pressure: 100 PSI
Float: Stainless Steel
Body: Clear Acrylic
Seals: Buna N
Fittings: PVC



Flow Rate	Catalog Number		Flow Rate	Catalog Number	
	Panel Mount	In-Line		Panel Mount	In-Line
SCFM Air			GPM Water		
3 - 25	GF-5050-P	GF-5050-I	.4 - 5	GF-5156-P	GF-5156-I
4 - 50	GF-5051-P	GF-5051-I	1 - 10	GF-5157-P	GF-5157-I
10 - 100	GF-5052-P	GF-5052-I	2 - 20	GF-5158-P	GF-5158-I
SLPM Air			LPM Water		
100 - 700	GF-5053-P	GF-5053-I	1 - 15	GF-5159-P	GF-5159-I
100 - 1400	GF-5054-P	GF-5054-I	4 - 36	GF-5160-P	GF-5160-I
400 - 3400	GF-5055-P	GF-5055-I	5 - 75	GF-5161-P	GF-5161-I

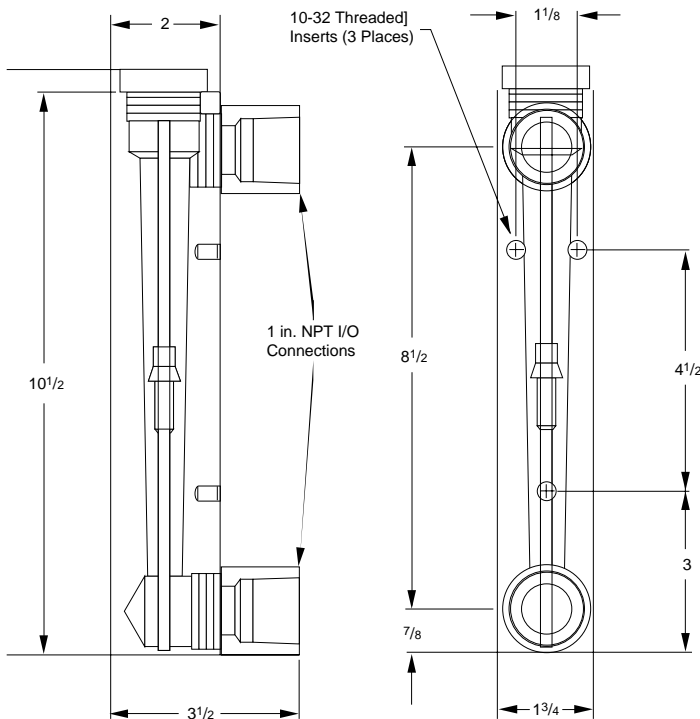

Inches	10-24/32	10-1/2	2	3-1/2	1" FNPT	8-1/2	7/8	1-1/8	4-1/2	3
MM	273	267	50.8	88.9	25.4	216	22.2	28.6	114	76.2

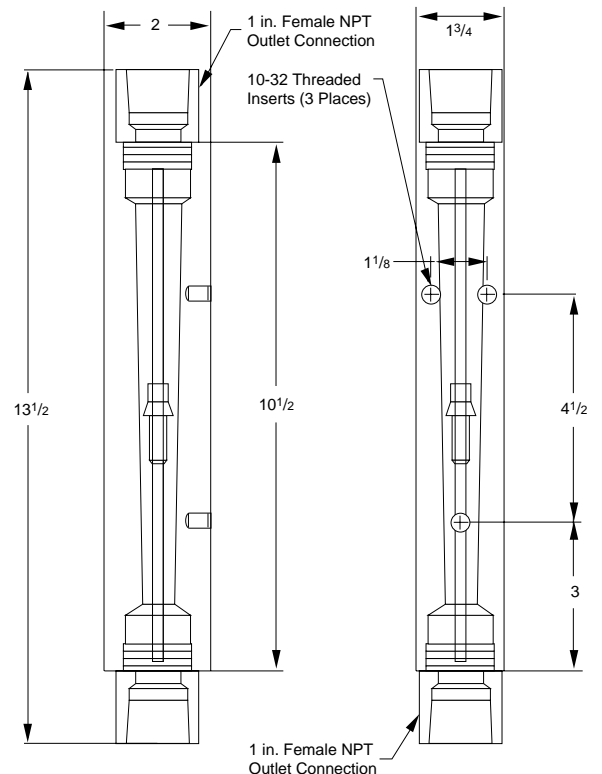

Inches	13-1/2	2	10-1/2	1" NPT(F)	1-1/8	1-3/4	4-1/2	3
MM	343	50.8	267	25.4	28.6	44.5	114	76.2

Fittings and Accessories

Barbed fittings are designed for quick and easy assembly without tools. Combine these simple, economical fittings with our flexible tubing for use in your low-pressure applications (generally under 30 psi).

Nylon fittings have good chemical resistance and withstand temperatures from -40°F to 200°F (-40°C to 93°C).

High-density polyethylene (HDPE) fittings have very good chemical resistance and withstand temperatures from -65°F to 190°F (-53°C to 87°C).

Polypropylene fittings have very good chemical resistance and withstand temperatures from 0°F to 275°F (-17°C to 135°C).

Barbed Fittings

NPT male pipe adapters

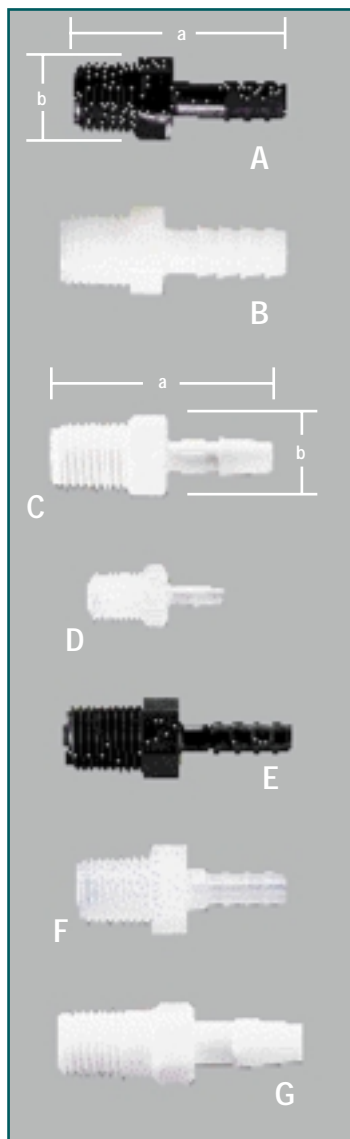

Key	Tubing ID	Material	Dimensions			Standard packs	
			a	b	Orifice	Catalog number	Qty/pk
NPT male pipe adapters, NPT(M) x tubing ID							
A	1/8" x 3/16"	HDPE	1 1/2"	7/16"	1/8"	6450-10	10
A	1/8" x 1/4"		1 1/2"	7/16"	1/8"	6450-11	10
A	1/8" x 5/16"		1 1/2"	7/16"	7/32"	6477-00	10
A	1/8" x 3/8"		1 1/2"	7/16"	1/4"	6450-12	10
A	1/4" x 3/16"	HDPE	1 5/8"	9/16"	1/8"	6450-20	10
A	1/4" x 5/16"		1 5/8"	9/16"	7/32"	6477-01	10
A	1/4" x 3/8"		1 5/8"	9/16"	1/4"	6450-30	10
A	1/4" x 1/2"	HDPE	1 5/8"	9/16"	11/32"	6450-31	10
A	3/8" x 5/16"		1 5/8"	11/16"	7/32"	31600-13	10
A	3/8" x 3/8"		1 5/8"	11/16"	1/4"	6450-40	10
A	3/8" x 1/2"	HDPE	1 5/8"	11/16"	3/8"	6450-41	10
A	3/8" x 5/8"		1 5/8"	11/16"	15/32"	6477-02	10
B	1/8" x 3/16"	Nylon	1 1/2"	7/16"	1/8"	6465-10	10
B	1/8" x 1/4"		1 1/2"	7/16"	1/8"	6465-15	10
B	1/8" x 5/16"		1 1/2"	7/16"	7/32"	6478-00	10
B	1/8" x 3/8"		1 1/2"	7/16"	1/4"	6465-20	10
B	1/4" x 3/16"	Nylon	1 5/8"	9/16"	1/8"	6465-25	10
B	1/4" x 1/4"		1 5/8"	9/16"	5/32"	6465-30	10
B	1/4" x 5/16"		1 5/8"	9/16"	7/32"	6478-01	10
B	1/4" x 3/8"		1 5/8"	9/16"	1/4"	6465-35	10
B	1/4" x 1/2"	Nylon	1 5/8"	9/16"	11/32"	6465-40	10
B	3/8" x 1/4"		1 5/8"	11/16"	5/32"	6465-45	10
B	3/8" x 5/16"		1 5/8"	11/16"	7/32"	31700-13	10
B	3/8" x 3/8"		1 5/8"	11/16"	1/4"	6465-50	10
B	3/8" x 1/2"	Nylon	1 5/8"	11/16"	3/8"	6465-55	10
B	3/8" x 5/8"		1 5/8"	11/16"	15/32"	6478-02	10
NPT male pipe adapters, NPT(M) x tubing ID—continued							
C	1/8" x 1/4"	White PP	1 1/2"	1/2"	1/8"	30610-36	10
C	1/8" x 3/8"		1 19/32"	1/2"	1/4"	30610-37	10
C	1/4" x 1/4"		1 23/32"	21/32"	1/8"	30610-38	10
C	1/4" x 3/8"		1 13/16"	21/32"	1/4"	30610-39	10
C	1/4" x 1/2"	White PP	1 29/32"	21/32"	11/32"	30610-40	10
C	3/8" x 1/4"		1 23/32"	13/16"	1/8"	30610-41	10
C	3/8" x 3/8"		1 13/16"	13/16"	1/4"	30610-42	10
C	3/8" x 1/2"		1 29/32"	13/16"	11/32"	30610-43	10
D	1/8" x 1/16"	Clear PP	31/32"	7/16"	1/32"	6365-41	25
D	1/8" x 3/32"		1"	7/16"	1/16"	6365-42	25
D	1/8" x 1/8"		1 3/32"	7/16"	1/16"	6365-43	25
E	3/16" x 1/8"	Black PP	1 17/32"	7/16"	3/32"	6444-16	10
E	3/16" x 1/4"		1 3/4"	9/16"	3/32"	6444-18	10
F	1/8" x 5/32"	Teflon® PFA	1 7/16"	1/2"	1/16"	6373-90	1
F	1/8" x 1/4"		1 9/16"	5/8"	1/8"	6373-91	1
F	1/4" x 1/4"		1 9/16"	5/8"	1/8"	6373-92	1
F	1/4" x 3/8"	PFA	1 9/16"	5/8"	1/4"	6373-93	1
F	3/8" x 3/8"		1 9/16"	1 3/16"	1/4"	6373-94	1
G	1/8" x 6 mm	PTFE	38 mm	13 mm	4 mm	6362-40	1
G	1/4" x 8 mm		48 mm	14 mm	5 mm	6362-50	1
G	1/4" x 10 mm		49 mm	16 mm	7 mm	6362-60	1
NPT male pipe adapters (NPT x tubing ID) continued on next page.							

Use compression fittings with rigid tubing. Compression fittings withstand higher pressures than barbed fittings and generally require no tools for installation.

Chemflour® Teflon® PFA fittings have superior chemical resistance; withstand temperatures from 32°F to 248°F (0°C to 120°C) and pressure to 135 psi; include PFA bodies, PFA ferrules, and Tefzel® nuts.

Compression Fittings

Male pipe adapters (straight)

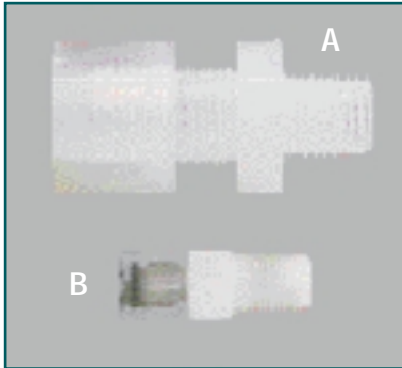

Key	Tubing OD x NPT	Material	Dimensions			Standard packs	
			a	b	Orifice	Catalog number	Qty/pk
Male pipe adapters (straight)							
A	1/8" x 1/8"	Teflon® PFA	1 ²³ / ₃₂ "	9/16"	1/16"	31000-40	1
A	1/8" x 1/4"		1 ²⁵ / ₃₂ "	9/16"	1/16"	31000-41	1
A	1/4" x 1/8"		1 ²⁷ / ₃₂ "	13/16"	5/32"	31000-42	1
A	1/4" x 3/8"		2"	13/16"	5/32"	31000-43	1
A	1/4" x 1/2"	PFA	2 ³ / ₃₂ "	13/16"	5/32"	31000-44	1
A	3/8" x 1/4"		2 ⁵ / ₃₂ "	2 ⁹ / ₃₂ "	5/16"	31000-45	1
A	1/2" x 1/4"		2 ⁹ / ₃₂ "	1 1/16"	5/32"	31000-46	1
A	3/4" x 1/2"		2 ¹³ / ₃₂ "	1 11/32"	13/32"	31000-47	1
A	1/4" x 1/4"	PFA	1 7/8"	2 ⁵ / ₃₂ "	5/32"	6379-50	1
A	3/8" x 1/4"		1 31/32"	2 ⁹ / ₃₂ "	1/4"	6379-51	1
A	3/8" x 3/8"		2"	2 ⁹ / ₃₂ "	1/4"	6379-52	1
A	1/2" x 3/8"		2"	1 1/16"	1 1/32"	6379-53	1
A	1/2" x 1/2"	PFA	2 ⁹ / ₃₂ "	1 1/16"	1 1/32"	6379-54	1
A	3/4" x 3/4"		2 1 ⁹ / ₃₂ "	1 11/32"	5/8"	6379-55	1
B	1/16" x 1/8"	PFA	1 ²¹ / ₃₂ "	1/2"	1/16"	6483-40	1
B	1/8" x 1/8"		1 5/8"	1/2"	1/16"	6374-01	1
B	1/8" x 1/4"		1 5/8"	5/8"	1/16"	6483-42	1
B	1/4" x 1/8"		1 ²³ / ₃₂ "	5/8"	3/16"	6374-02	1
B	1/4" x 1/4"	PFA	1 ²³ / ₃₂ "	5/8"	3/16"	6374-03	1
B	1/4" x 3/8"		1 ²³ / ₃₂ "	13/16"	3/16"	6483-44	1
B	1/4" x 1/2"		1 ¹³ / ₁₆ "	13/16"	3/16"	6483-45	1
B	5/16" x 1/4"		1 3/4"	1 1/16"	1/4"	6374-04	1
B	5/16" x 3/8"	PFA	1 3/4"	1 1/16"	1/4"	6483-46	1
B	3/8" x 1/8"		1 ¹³ / ₁₆ "	13/16"	3/16"	6483-48	1
B	3/8" x 1/4"		1 ¹³ / ₁₆ "	13/16"	9/32"	6374-05	1
B	3/8" x 3/8"		1 ¹³ / ₁₆ "	13/16"	9/32"	6374-06	1
B	3/8" x 1/2"	PFA	1 ¹⁵ / ₁₆ "	13/16"	9/32"	6483-50	1
B	1/2" x 1/4"		1 3/4"	1 ⁵ / ₁₆ "	9/32"	6483-52	1
B	1/2" x 3/8"		1 3/4"	1 ⁵ / ₁₆ "	13/32"	6374-07	1
B	1/2" x 1/2"		1 7/8"	1 ⁵ / ₁₆ "	7/16"	6374-08	1
B	1/2" x 3/4"	PFA	1 7/8"	1 3/16"	7/16"	6483-54	1
B	3/4" x 1/2"		2 1/16"	1 3/16"	1 1/32"	6483-55	1
B	3/4" x 3/4"		2 1/16"	1 3/16"	2 1/32"	6483-56	1
B	4 mm x 1/8"	PFA	42 mm	13 mm	2 mm	31103-10	1
B	4 mm x 1/4"		42 mm	13 mm	2 mm	31103-11	1
B	6 mm x 1/8"		43 mm	16 mm	5 mm	6375-30	1
B	6 mm x 1/4"		43 mm	16 mm	5 mm	6375-31	1

Trademarks

Accucal – Reg. TM of Barnant Company
 Viton – Reg. TM of E.I. Dupont de Nemours & Co.
 Gilmont – Reg. TM of Barnant Company
 Windows – Reg. TM of Microsoft Corp.
 95/98/NT – Reg. TM of Microsoft Corp.
 Chemflour – Reg. TM of St. Gobain Performance Plastics
 Teflon PFA – Reg. TM of E.I. Dupont de Nemours & Co.

NIST Certification Services

- **NEW! Directly from Gilmont®**
- **Certify your Flowmeters traceable to NIST standards.**
- **We can calibrate, certify and ship new Gilmont® Flowmeters to you, or send us your pre-owned meter for prompt and accurate certification.**

Gilmont® Instruments offers flowmeter calibrations traceable to the National Institute of Standards and Technology, (NIST). Our flow calibration facilities are reviewed under a system which complies with ANSI Z540-1, ISO 10012-1 and MIL-STD-45662A. Order 5 or 10 point Rotameter calibrations for Air or Nitrogen at standard conditions, (please specify float type, i.e., stainless, ruby, etc.)

For new meters simply order the appropriate meter, then the catalog # shown above. For recertifications, calibrations on other types of flowmeters, common gases, and/or specific conditions, please consult our Application Specialists for custom quotations.

697-5405, 5 pt.
 697-5405, 10 pt.



Contact your dealer or consult price list for service charge.